

Radial spherical plain bearings GE...HO-2RS

requiring maintenance, to DIN ISO 12 240-1, lip seals on both sides

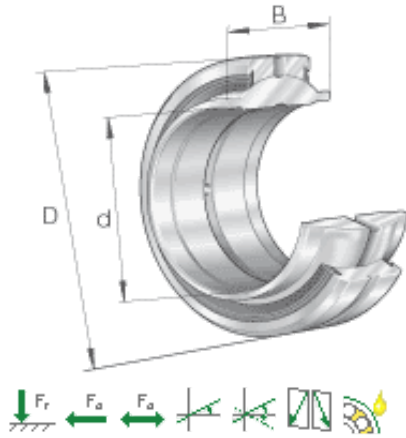

	d	D	B			
	mm	mm	mm			
GE20-HO-2RS	20	35	24			
GE25-HO-2RS	25	42	29			
GE30-HO-2RS	30	47	30			
GE35-HO-2RS	35	55	35			
GE40-HO-2RS	40	62	38			
GE45-HO-2RS	45	68	40			
GE50-HO-2RS	50	75	43			
GE60-HO-2RS	60	90	54			
GE70-HO-2RS	70	105	65			
GE80-HO-2RS	80	120	74			

d D B
mm mm mm