

## Radial spherical plain bearings GE...-UK-2RS

maintenance-free, to DIN ISO 12 240-1, lip seals on both sides

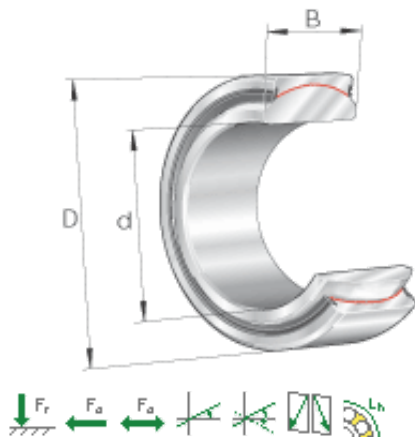

	d	D	B			
	mm	mm	mm			
<b>GE17-UK-2RS</b>	17	30	14			
<b>GE20-UK-2RS</b>	20	35	16			
<b>GE25-UK-2RS</b>	25	42	20			
<b>GE30-UK-2RS</b>	30	47	22			
<b>GE35-UK-2RS</b>	35	55	25			
<b>GE40-UK-2RS</b>	40	62	28			
<b>GE45-UK-2RS</b>	45	68	32			
<b>GE50-UK-2RS</b>	50	75	35			
<b>GE60-UK-2RS</b>	60	90	44			
<b>GE70-UK-2RS</b>	70	105	49			
<b>GE80-UK-2RS</b>	80	120	55			
<b>GE90-UK-2RS</b>	90	130	60			
<b>GE100-UK-2RS</b>	100	150	70			
<b>GE110-UK-2RS</b>	110	160	70			
<b>GE120-UK-2RS</b>	120	180	85			
<b>GE140-UK-2RS</b>	140	210	90			
<b>GE160-UK-2RS</b>	160	230	105			
<b>GE180-UK-2RS</b>	180	260	105			
<b>GE200-UK-2RS</b>	200	290	130			
<b>GE220-UK-2RS</b>	220	320	135			
	<b>d</b>	<b>D</b>	<b>B</b>			
	mm	mm	mm			
<b>GE240-UK-2RS</b>	240	340	140			
<b>GE260-UK-2RS</b>	260	370	150			
<b>GE280-UK-2RS</b>	280	400	155			
<b>GE300-UK-2RS</b>	300	430	165			